

Reinforcing Layer

SECTION A-A

RECOMMENDED FFC/FPC DIMENSION

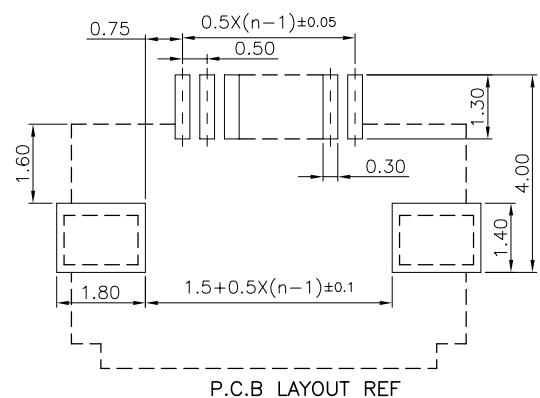
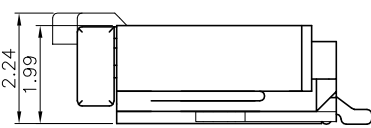
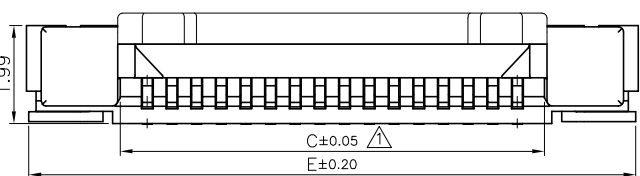

P.C.B LAYOUT REF

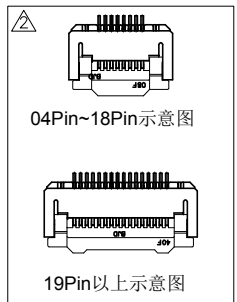
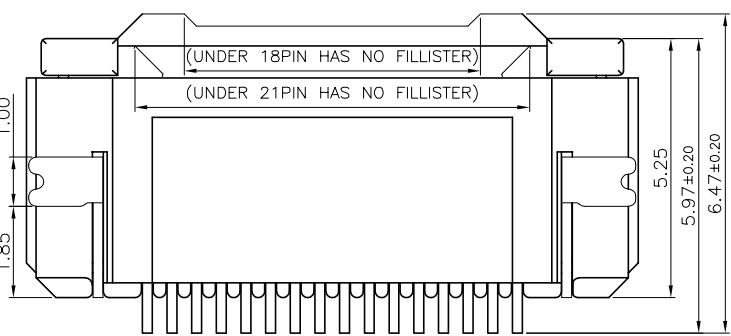

4.PART NO. SPECIFICATION:101005-XOXXXO

- 1:管装
- 2:亮锡
- 3:袋装
- 4:其他
- 5:雾锡
- 6:镀金1u'
- 7:镀金3u'
- 8:半金锡

NO. of contacts (n)	Dimensions				
	A	B	C	D	E
4	6.40	5.80	2.57	1.50	6.30
5	6.90	6.30	3.07	2.00	6.80
6	7.40	6.80	3.57	2.50	7.30
7	7.90	7.30	4.07	3.00	7.80
8	8.40	7.80	4.57	3.50	8.30
9	8.90	8.30	5.07	4.00	8.80
10	9.40	8.80	5.57	4.50	9.30
11	9.90	9.30	6.07	5.00	9.80
12	10.40	9.80	6.57	5.50	10.30
13	10.90	10.30	7.07	6.00	10.80
14	11.40	10.80	7.57	6.50	11.30
15	11.90	11.30	8.07	7.00	11.80
16	12.40	11.80	8.57	7.50	12.30
17	12.90	12.30	9.07	8.00	12.80
18	13.40	12.80	9.57	8.50	13.30
19	13.90	13.30	10.07	9.00	13.80
20	14.40	13.80	10.57	9.50	14.30
21	14.90	14.30	11.07	10.00	14.80
22	15.40	14.80	11.57	10.50	15.30
23	15.90	15.30	12.07	11.00	15.80
24	16.40	15.80	12.57	11.50	16.30
25	16.90	16.30	13.07	12.00	16.80
26	17.40	16.80	13.57	12.50	17.30
27	17.90	17.30	14.07	13.00	17.80
28	18.40	17.80	14.57	13.50	18.30
29	18.90	18.30	15.07	14.00	18.80
30	19.40	18.80	15.57	14.50	19.30
31	19.90	19.30	16.07	15.00	19.80
32	20.40	19.80	16.57	15.50	20.30
33	20.90	20.30	17.07	16.00	20.80
34	21.40	20.80	17.57	16.50	21.30
35	21.90	21.30	18.07	17.00	21.80
36	22.40	21.80	18.57	17.50	22.30
37	22.90	22.30	19.07	18.00	22.80
38	23.40	22.80	19.57	18.50	23.30
39	23.90	23.30	20.07	19.00	23.80
40	24.40	23.80	20.57	19.50	24.30
41	24.90	24.30	21.07	20.00	24.80
42	25.40	24.80	21.57	20.50	25.30
43	25.90	25.30	22.07	21.00	25.80
44	26.40	25.80	22.57	21.50	26.30
45	26.90	26.30	23.07	22.00	26.80
46	27.40	26.80	23.57	22.50	27.30
47	27.90	27.30	24.07	23.00	27.80
48	28.40	27.80	24.57	23.50	28.30
49	28.90	28.30	25.07	24.00	28.80
50	29.40	28.80	25.57	24.50	29.30
51	29.90	29.30	26.07	25.00	29.80
52	30.40	29.80	26.57	25.50	30.30
53	30.90	30.30	27.07	26.00	30.80
54	31.40	30.80	27.57	26.50	31.30
55	31.90	31.30	28.07	27.00	31.80
56	32.40	31.80	28.57	27.50	32.30
57	32.90	32.30	29.07	28.00	32.80
58	33.40	32.80	29.57	28.50	33.30
59	33.90	33.30	30.07	29.00	33.80
60	34.40	33.80	30.57	29.50	34.30

- NOTES:
- HOUSING MATERIAL: HEAT RESISTANT PLASTIC UL94 V-0.  
ACTUATOR MATERIAL: HEAT RESISTANT PLASTIC UL94 V-0.
  - TERMINAL MATERIAL: PHOSPHOR BRONZE.  
2-1.PLATED WITH BRIGHT TIN(100%) 80u"~150u"  
2-2.PLATED WITH MATTE TIN(100%) 80u"~150u"  
2-3.PLATED WITH GOLD MORE THAN 1u.
  - FITTING NAIL MATERIAL: BRASS.  
3-1.PLATED WITH BRIGHT TIN(100%) 80u"~150u"  
3-2.PLATED WITH MATTE TIN(100%) 80u"~150u"

SER	REVISIONS	CHK	DATE	UNIT	MM

UNLESS OTHERWISE SPECIFIED TOLERANCES ARE	
X.	±0.20
X.X	±0.10
X.XX	±0.05
X.XXX	±0.03
ANG.	±0°30'

客户图 Drawings		北极大电子科技有限公司 BEIJIDA ELECTRONICS TECHNOLOGY CO. LIMITED		
APPROVED	DATE	COMPUTER NO		
陈天舒	2012-05-20	101005-XOXXXO		
CHECKED	DATE	NAME		
陈天舒	2012-05-20	FPC0.5-3代H2.0掀盖式成品		
DRAWN	DATE	SIZE	SCALE	REV
张运兴	2012-05-20	A4	8:1	C

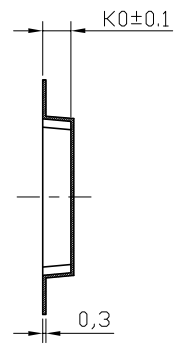
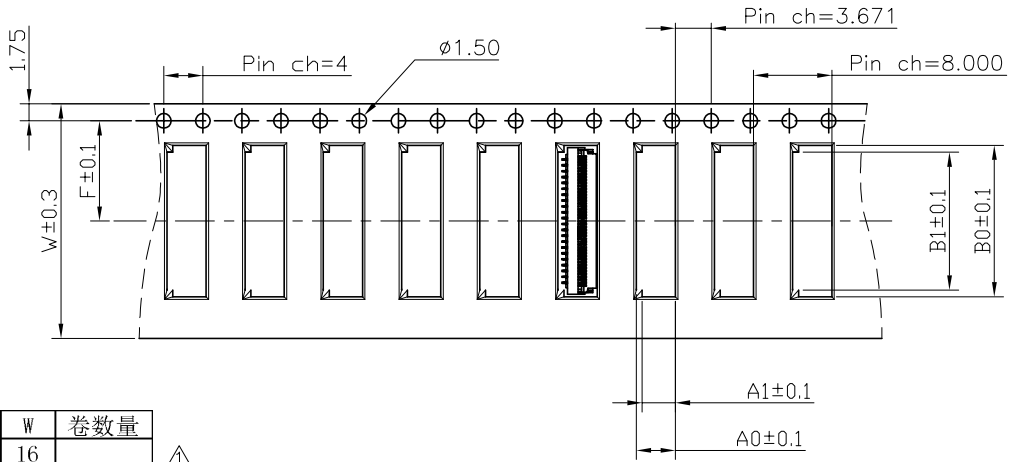

P数	A0	A1	B0	B1	K0	F	W	卷数量
11			5.30	3.90		6.25	16	
13			5.90	4.50		6.25	16	
15			6.50	5.10		6.25	16	
17			7.10	5.70		6.25	16	
19			7.70	6.30		6.25	16	
21			8.30	6.90		6.25	16	
23			8.90	7.50		6.25	16	
25			9.50	8.10		6.25	16	
27			10.10	8.70		10.25	24	
29			10.70	9.30		10.25	24	
31			11.30	9.90		10.25	24	
33			11.90	10.50		10.25	24	
35			12.50	11.10		10.25	24	
37			13.10	11.70		10.25	24	
39			13.70	12.30		10.25	24	
41	4.00	3.40	14.30	12.90	1.50	10.25	24	5000PCS /卷
43			14.90	13.50		10.25	24	
45			15.50	14.10		10.25	24	
47			16.10	14.70		10.25	24	
49			16.70	15.30		10.25	24	
51			17.30	15.90		14.25	32	
53			17.90	16.50		14.25	32	
55			18.50	17.10		14.25	32	
57			19.10	17.70		14.25	32	
59			19.70	18.30		14.25	32	
61			20.30	18.90		14.25	32	
63			20.90	19.50		14.25	32	
65			21.50	20.10		14.25	32	
67			22.10	20.70		20.25	44	
69			22.70	21.30		20.25	44	
71			23.30	21.90		20.25	44	
73			23.90	22.50		20.25	44	



User Direction of Unreeling

PART NO. SPECIFICATION: 14000X-20XXX0

1:黑色	PIN数	1:雾锡
2:本色		2:亮锡
1:管装	PIN数	3:镀金1u'
2:卷装		4:镀金3u'
3:袋装		5:半金锡3u'
4:其他		6:半金锡1u'

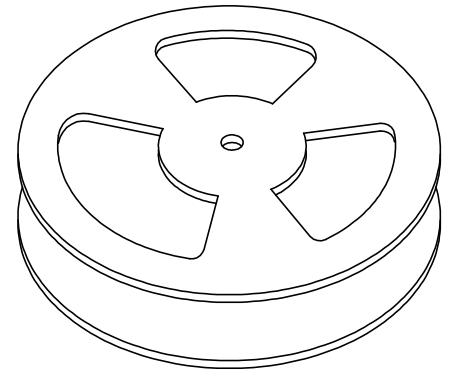

				UNLESS OTHERWISE SPECIFIED TOLERANCES ARE		包装图		北极大电子科技有限公司				
						Packaging Figure		BEIJIDA ELECTRONICS TECHNOLOGY CO. LIMITED				
				X.		APPROVED		DATE		COMPUTER NO		
				X.X ±0.1				2014-03-31		14000X-20XXX0		
				X.XX ±0.05		CHECKED		DATE		NAME		
				X.XXX		陈天舒		2014-03-31		FPC0.3-3代掀盖式卷装图		
				ANG. ±0°30'		DRAWN		DATE		SIZE	SCALE	REV
△ 修改PIN数表				刘丽平	2014-4-8	刘丽平		2014-03-31		A4	3:4	B
SER	REVISIONS	CHK	DATE	UNIT	MM							